

TECHNICAL SPECIFICATION C640D-305-120TH

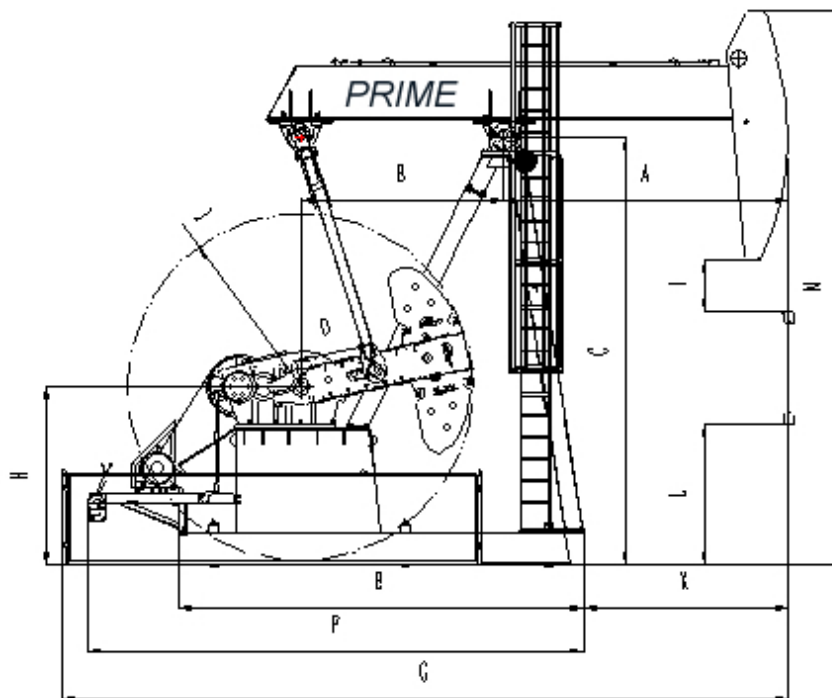

General dimension (in)												
A	B	C	D	E	F	G	H	I	J	K	L	M
155	111	232	42	224	275	392	96	31.5	94	112	72	302
General data												
Model									C640D-305-120TH			
Polish Rod Capacity(lbs)									30500			
Stroke Lengths(in)									120	102	85	
Strokes Frequency(min ⁻¹)									6	8	10	
Balance Mode									Crank balance			
Base type									TH			
Gear box	Model								JS-640			
	Reducer Ratio								28.363			
	Peak Torque Rating(lbs .in)								640000			
	Gear type								DCA			
Motor	Model								YCH280-6			
	Power(HP)								75			
	Rotational speed(r/min)								1000			
Structural unbalance(lbs)									+379			
Counter balance effect(lbs)									18253			
Outline Dimensions (Length×Width×Height) (in×in×in)									386×104×302			
Total weight(lbs)									52580			
Note :the outline dimensions excluding crank guards, the total weight excluding electric motor												