

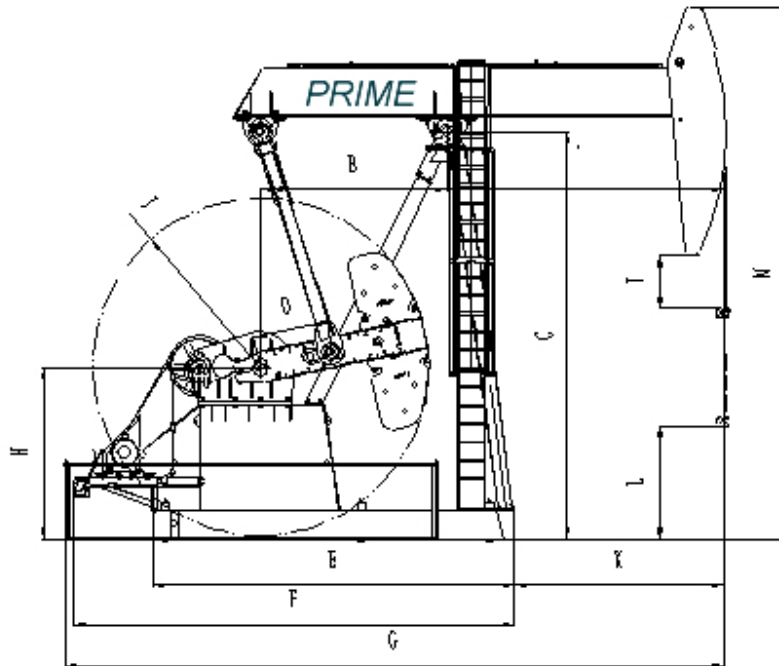

## TECHNICAL SPECIFICATION C912D-365-168TH



General dimension (in)												
A	B	C	D	E	F	G	H	I	J	K	L	M
209	120	262	46.9	242.7	300	472	111	20.5	108	166	70.7	355
General data												
Model									C912D-365-168TH			
Polish Rod Capacity(lbs)									36500			
Stroke Lengths(in)									168 141 115			
Strokes Frequency(min <sup>-1</sup> )									9 11 13			
Balance Mode									Crank balance			
Base type									TH			
Gear box	Model								JS-912			
	Reducer Ratio								28.79			
	Peak Torque Rating( lbs .in)								912000			
	Gear type								DCA			
	Sheave								50"C-7			
Motor	Model								Y315S-6			
	Power(kW)								75			
	Rotational speed( r/min)								970			
Structural unbalance( lbs)									-871			
Outline Dimensions (Length×Width×Height) (in×in×in)									449×104×355			
Counter balance effect( lbs)									22426			
Total weight( lbs)									73788			
Note :the total weight excluding motor ;the outline dimensions excluding crank guards												

Tel: +86-546-8279101, Fax: +86-546-8279181

Email: [petroleum@sino-prime.com](mailto:petroleum@sino-prime.com)

<http://www.shengli-petroleum.com>